

Longitudinal Study of American Youth

SCIENCE

(Form E)

INTRODUCTION

This booklet contains questions about science for you to answer. You will be able to answer some of the questions quickly and others will require more thought. Please do not feel discouraged if you are not absolutely sure of an answer. Some questions will ask about things you have covered in class, but others will not. Please do your best to answer each question. If you are not sure of the answer, read the question again, and make your best guess.

MARKING YOUR ANSWERS

Each question is followed by a set of possible answers labeled A, B, C, etc. Read each question carefully, then choose the *one* answer you think is the best, and darken in the letter on your *Answer Sheet* next to the number for that question. Be sure to mark only *one* letter for each question. Do not skip any questions.

Do not make any stray marks on your *Answer Sheet*. Do all of your calculations on the Question Booklet, and use the *Answer Sheet* only to record your answers.

If you have any questions while taking this test, raise your hand, and the person giving the test will come to your seat to help you.

1. Ten plants were placed in sandy soil and ten others were placed in clay soil. Both groups of plants were kept at room temperature, given the same amount of water, and placed in a sunny room. This experiment tests the effect of
- (A) sunlight on plant growth. (C) different soils on plant growth.
(B) temperature on plant growth. (D) water on plant growth. N413401
2. In which of the following states of matter are the molecules generally most tightly packed?
- (A) Solid (B) Liquid (C) Gas N419801
3. Can you see a single atom with the unaided eye?
- (A) Yes (B) No N404801
4. What is the probability that two people who are hybrid for brown eyes (Bb) will have a blue-eyed child? (B = genes for brown eye color; b = genes for blue eye color)
- (A) 0% (C) 50%
(B) 25% (D) 75% N432601

5.

ENERGY USE IN FOOD SYSTEM *VERSUS*
ENERGY OF FOOD PRODUCED

(Energy of food produced is
population times 11.30 kJ per day.)

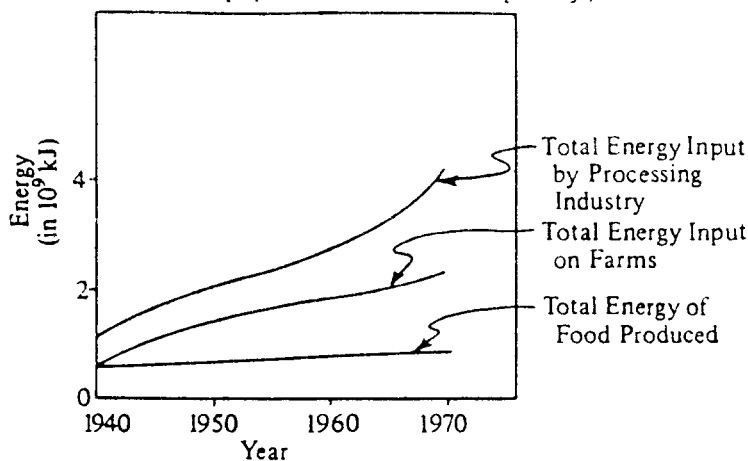

According to the graph above, when and where did the largest increase in the amount of energy used for the production of food occur?

- (A) In the processing industry between 1940 and 1950
(B) In the processing industry between 1960 and 1970
(C) On the farms between 1940 and 1950
(D) On the farms between 1960 and 1970 N436001
6. Due to the expansion of our universe, the wavelengths of the light from the most distant stars are shifted to longer wavelengths. A combination of which two of the following instruments could be used to measure this property of the distant stars?
- I. Telescope
II. Microscope
III. Spectrometer
IV. Thermometer
- (A) I and II (C) II and III
(B) I and III (D) III and IV N418001

7. To which of the following animals is the wolf most closely related?

- (A) Buffalo
(B) Deer

- (C) Dog
(D) Rabbit

(E) Sheep

N404501

8.

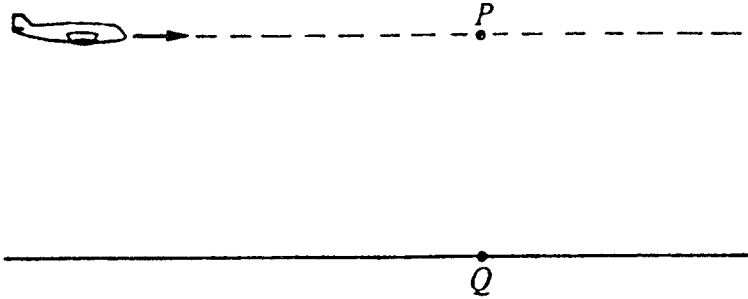

An airplane flies in a straight level line at constant speed as shown above. A package is to be dropped from the plane so that it hits a target at point Q . Point P is directly over the target. When should the package be dropped?

- (A) At a certain time before the plane reaches point P
 (B) At the instant that the plane reaches point P
 (C) Immediately after the plane passes point P
 (D) Several seconds after the plane has passed point P

N422201

► **Questions 9-10.** In two different places in a museum of natural history, you may find the following combinations.

Place 1: Aspen trees, beaver, blue jays and deer

Place 2: Rattlesnakes, alligators and turtles

9. The things in Place 1 are probably grouped together because

- (A) they are found in the same area in nature.
 (B) people enjoy looking at them.
 (C) they were collected at about the same time.
 (D) they were all alive once.

N404701

10. The things in Place 2 are probably grouped together because

- (A) they are found in the same area in nature.
 (B) people enjoy looking at them.
 (C) they have similar characteristics.
 (D) they eat the same kinds of food.

N404702

11. Polaris, the North Star, will appear most directly overhead to an observer at which of the following places in the Northern Hemisphere?

- (A) Near the equator
(B) In Miami

- (C) In Seattle
(D) Near the North Pole

N420601

- **Questions 12-13.** Two flames of the same size were used to heat the two pans of water shown below. Both pans were heated until they reached 90 degrees Celsius.

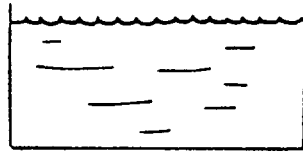

Pan 1

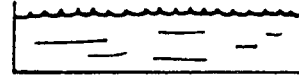

Pan 2

12. In which pan did the temperature reach 90 degrees first?
- (A) Pan 1
(B) Pan 2
(C) Both at the same time
- N404901
13. Which pan cooled down the fastest when the flame was turned off?
- (A) Pan 1
(B) Pan 2
(C) Both at the same time
- N404903
-
14. Which of the following best explains why marine algae are most often restricted to the top 100 meters in the ocean?
- (A) They have no roots to anchor them to the ocean floor.
(B) They are photosynthetic and can live only where there is light.
(C) The pressure is too great for them to survive below 100 meters.
(D) The temperature of the top 100 meters of the ocean is ideal for them.
- N432901
15. Beaker I contains 200 milliliters of water and beaker II contains 400 milliliters of water. Both beakers are initially at 25°C.
- If the two beakers are heated at the same constant rate for 2 minutes, how will the temperature of the water in them compare?
- (A) It will be higher in beaker I than in beaker II.
(B) It will be higher in beaker II than in beaker I.
(C) It will be the same in both beakers.
- N423901
16. The volume of water put into a tank is equal to the rate of flow multiplied by the time it flows. An equation that shows this relationship is
- (A) volume = rate \times time.
(B) rate = volume \times time.
(C) time = rate \times volume.
(D) time = rate/volume.
(E) volume = time/rate.
- N409301

- **Questions 17-21.** A theory in geology says that huge sections of the earth's crust move around very slowly. Does this theory help us answer each of the following questions?

- | | Yes | No | |
|---|-----|-----|---------|
| 17. How are mountains formed? | (A) | (B) | N406401 |
| 18. What will tomorrow's weather be like? | (A) | (B) | N406402 |
| 19. What causes earthquakes? | (A) | (B) | N406403 |
| 20. How do continents move? | (A) | (B) | N406404 |
| 21. Where did the moon come from? | (A) | (B) | N406405 |

22. This diagram represents a cross-section of one part of the earth's crust. Layers 1, 2, 3 and 4 are each different kinds of rock.

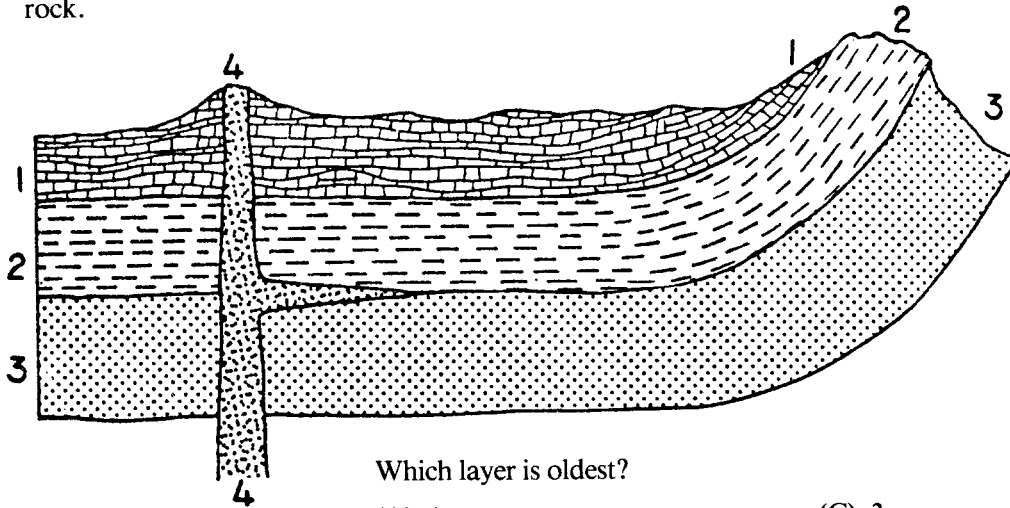

Which layer is oldest?

- (A) 1 (B) 2 (C) 3 (D) 4

N407301

23. The pedigree chart below shows the occurrence of a hypothetical inherited disease.

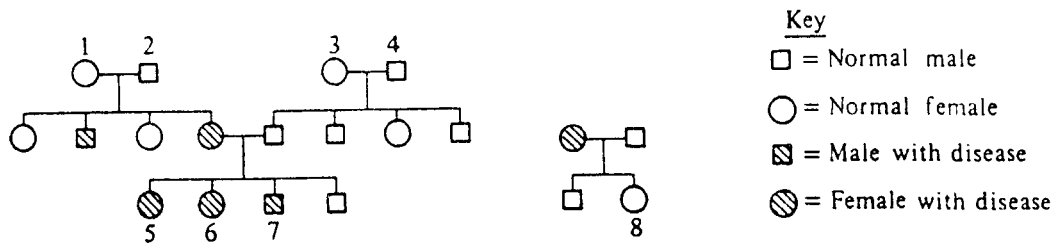

If Individual 7 marries Individual 8, what is the chance that any of their children will have the disease?

- (A) 0 (B) 25% (C) 50% (D) 100%

N430003

24. Our solar system contains all of the following EXCEPT

- (A) Earth. (B) Mars. (C) the Sun. (D) the Moon. (E) the North Star.

N406601

25. The shape of the Earth's shadow during an eclipse of the Moon indicates that the shape of the Earth could be like which of the following?

- (A) A cylinder (B) A doughnut (C) A pyramid (D) A cube

N429201

26. Half-life is a measure of

- (A) distance. (B) mass. (C) time. (D) temperature. (E) color.

N407001

27. Scientists today agree on many ideas about how the natural world works. Which of the following is a scientific attitude toward these ideas?

- (A) Some of the ideas will probably have to change when scientists have more information.
 (B) Most ideas will not be changed for a very long time to come.
 (C) All of the ideas will have to change to keep up with fast-moving world events.
 (D) None of the ideas will be changed because they are scientific ideas.

N435001

28. A teacher left a plant in a dark classroom during the school's ten day spring break. She placed a light near the plant, and she watered the plant well. When students returned to school after spring break, what do you think the plant looked like?

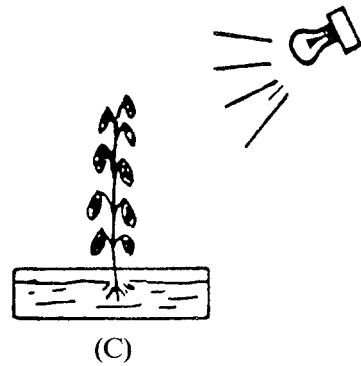
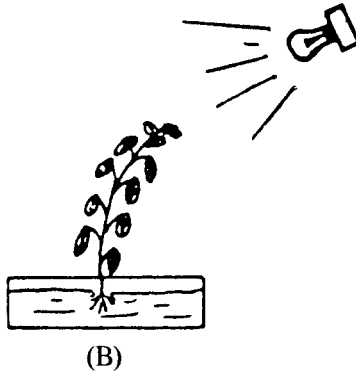
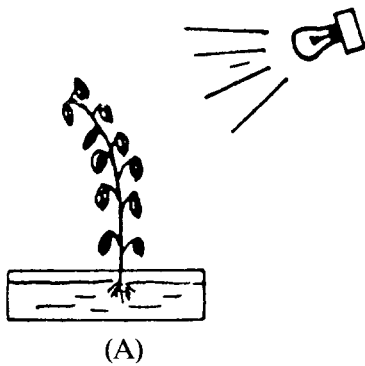

N401201

- 29.

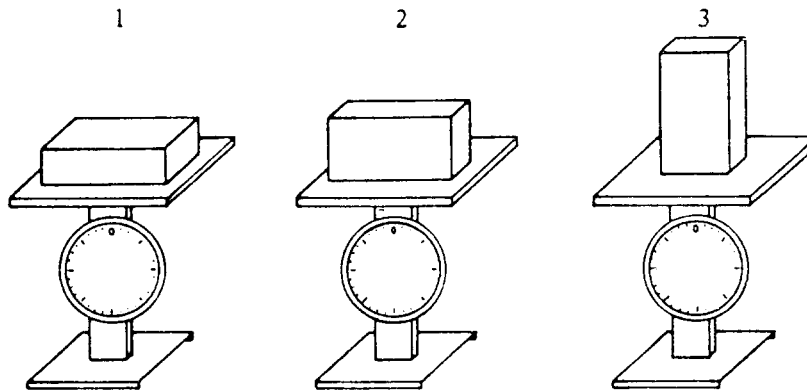

A brick can be set on a scale in three different positions, as shown above. In which position will the brick weigh the most?

- (A) 1
 (B) 2
 (C) 3
 (D) The brick will weigh the same in all three positions. N434401
30. Why can astronauts wearing space suits jump much higher on the Moon than on the Earth?
- (A) The pull of gravity on the Moon is much less than it is on the Earth.
 (B) There is no air on the Moon.
 (C) Their spacesuits help them to jump farther.
 (D) The Moon has less magnetism than the Earth has. N413001
31. Can you see a single atom with a magnifying glass?
- (A) Yes (B) No N404802
32. If the temperature drops during the night, the air pressure in an automobile tire
- (A) increases.
 (B) decreases.
 (C) increases or decreases, depending on the humidity.
 (D) stays the same. N410701

33. An artificial satellite travels in an easterly direction and orbits the Earth every 6 hours. To an observer in the central United States, the satellite would appear to

- (A) rise in the east and set in the west
- (B) rise in the west and set in the east
- (C) remain stationary above the observer's position

N434801

34. Which of the following animals does NOT lay eggs?

- (A) Ostrich
- (B) Frog
- (C) Mouse
- (D) Turtle

N412101

35.

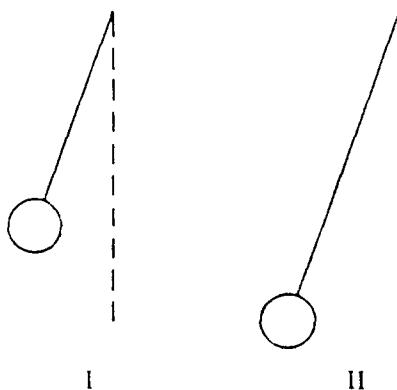

The bobs of two pendulums shown above have the same masses and volumes. The string of pendulum I is 100 centimeters long and the string of pendulum II is 150 centimeters long.

A student holds each bob at its starting angle of 20° , and then releases both bobs simultaneously.

How does the period (time for one complete swing) of pendulum I compare with the period of pendulum II?

- (A) The period of pendulum I is greater.
- (B) The periods of pendulums I and II are the same.
- (C) The period of pendulum II is greater.

N424901

36.

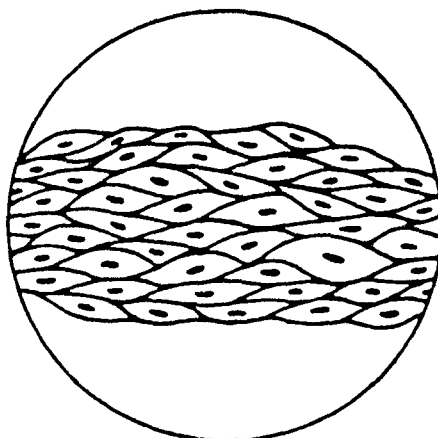

A group of cells looks like this under a microscope.

These cells all work together to do the same thing. A group of cells like this is called

- (A) a tissue.
- (B) an organism.
- (C) an organ.
- (D) a system.

N405001

37. Animal bones, seashells, and a certain mineral, all found in shallow ocean water, combine to form the rock limestone. Limestone is found in the state of Ohio. What would this information lead scientists to conclude about Ohio?

- (A) Ohio is a good area for geologists.
- (B) An unusual number of animals died in Ohio in the past.
- (C) Part of Ohio was probably once covered by an ocean.
- (D) Many fish live in Ohio.

N416401

38.

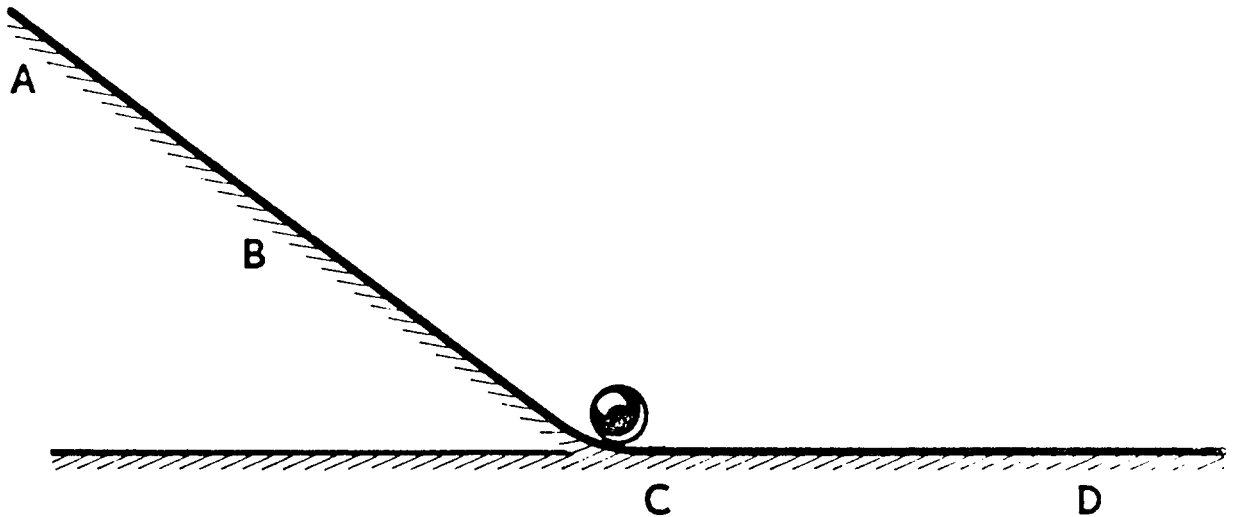

A ball rolls down a wooden ramp from A to C and onto a level wooden surface. Which one of the following statements about the speed of the ball at C is sure to be true?

- (A) The speed at C is faster than it will be at D.
- (B) The speed at C is the same as it was at B.
- (C) The speed at C is the same as it will be at D.
- (D) The speed at C is slower than at B.

N406701

39. Which of the following is NOT an accurate statement with regard to the drinking of alcoholic beverages?

- (A) Alcohol is a major source of energy for the body.
- (B) Alcohol slows down sensory perception and reflexes.
- (C) Alcoholics are people who are addicted to alcohol.
- (D) Excessive use of alcohol can cause liver disease.

N419201

40.

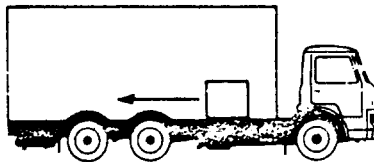

The truck shown above accelerates quickly to the right. If the floor of the trailer is slippery enough so there is little friction, a package inside the truck slides to the back. What does this illustrate?

- (A) Objects at rest remain at rest unless acted on by a force.
- (B) Mass can be converted to energy.
- (C) All objects have weight.
- (D) The total energy of an object always remains the same.

N425001

41. Can you see a single atom with an ordinary microscope?
- (A) Yes (B) No
- N404803
42. If a stone is a diamond, it can scratch glass. Stone A cannot scratch glass. Which of the following statements about stone A is true?
- (A) It is a diamond.
(B) It is not a diamond.
(C) There isn't enough information to tell whether or not it is a diamond.
- N413201
43. Suppose you believe that all blue objects will sink in water. How should you go about testing this idea?
- (A) Look for white objects that float.
(B) Look for white objects that sink.
(C) Look for blue objects that sink.
(D) Look for blue objects that float.
- N413701
44. As a spaceship approaches the Earth, it begins to get hot and glow. Which of the following best explains why this happens?
- (A) The increasing force of gravity causes the spaceship to become hot.
(B) Friction heats the spaceship as it passes through the Earth's atmosphere.
(C) Sunlight reflected from the spaceship's surface heats it.
(D) Electricity in the air heats up the spaceship.
- N413101
45. Which one of the following is the best conclusion you can make from this graph?

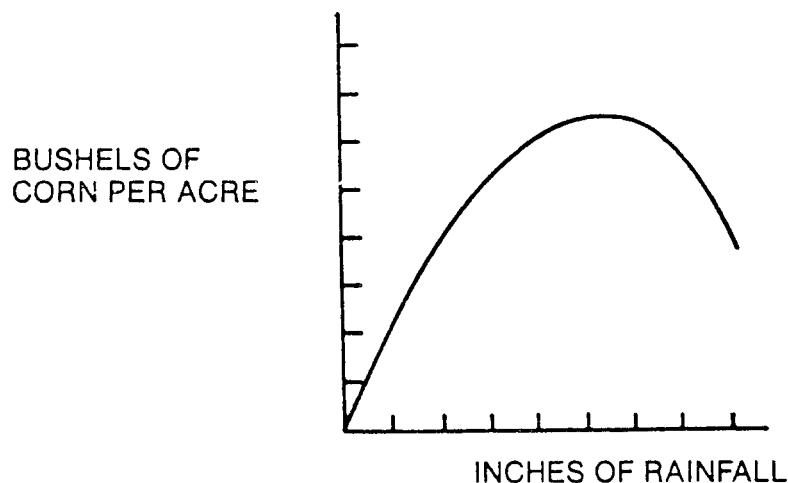

- (A) The more rain there is, the better the corn will grow.
(B) Corn needs rain to grow, but too much rain is harmful.
(C) Different kinds of corn need different amounts of rain to grow best.
(D) Corn can grow well even if there is no rain.

46.

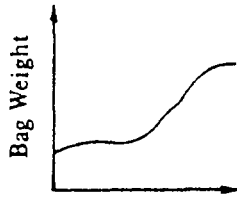

Time
Figure A

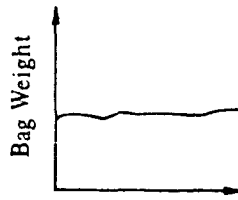

Time
Figure B

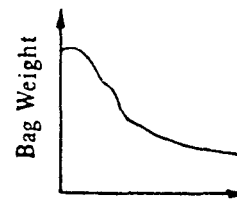

Time
Figure C

The graphs above indicate the gain or loss of weight of a dialysis bag over a period of time. A dialysis bag is made of a semipermeable material. Water moves through the material, but sugar does not.

Which graph represents a state of equilibrium in a dialysis bag?

(A) Figure A

(B) Figure B

(C) Figure C

N428102

47. Two astronauts walking on the moon are trying to communicate with each other. Which one of the following ways of communicating will not work for them?

(A) Ringing a bell

(C) Using a radio

(B) Flashing a light

(D) Waving

N406901

48. Acid rain is the result of the combination of pollution in the air and precipitation. Environmental action groups are advocating the control of acid rain by what means?

(A) Prohibiting industrialization wherever crops are grown

(B) Requiring workers to wear protective clothing

(C) Requiring industries to install antipollution filters and other devices

(D) Requiring that new industries locate in areas of low precipitation

N424701

49. One hundred pea seeds were put in Petri dishes and covered with wet paper towels. The dishes were put inside black plastic sacks and carefully divided between two temperature-controlled incubators set to different temperatures.

The experiment was apparently designed to study the effect of which of the following variables on the germination of pea seeds?

(A) Seed type

(C) Light

(B) Water

(D) Temperature

N431901

50. Which part of the blood carries most of the oxygen to the body?

(A) Plasma

(C) Red cells

(E) White cells

(B) Platelets

(D) Serum

N405201

51.

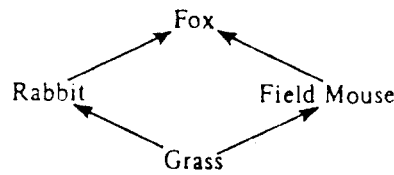

With respect to the field mouse in the food web above, what is the fox considered?

- (A) A predator
- (B) A prey
- (C) A producer
- (D) A decomposer

N418401

52.

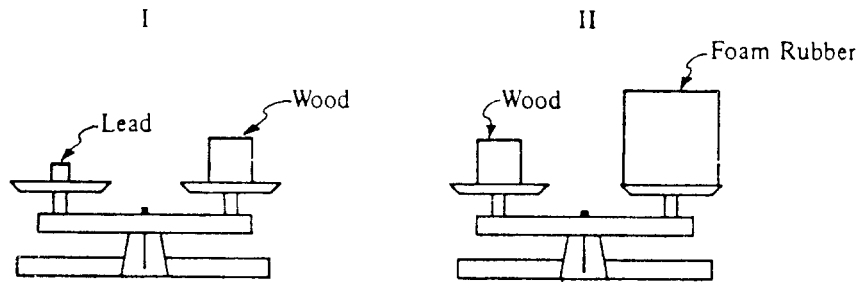

In Picture I, a piece of lead and a piece of wood are balanced on a scale, and in Picture II the same piece of wood is balanced with a piece of foam rubber. Which of the materials is most dense and which is least dense?

- | | |
|--|--|
| <p>Most Dense</p> <ul style="list-style-type: none"> (A) Wood (B) Lead (C) Foam rubber (D) Wood | <p>Least Dense</p> <ul style="list-style-type: none"> Lead Foam rubber Lead Foam rubber |
|--|--|

N434901

53. Some water plants, fish, snails, and other water animals were placed in a sealed aquarium as shown in the picture below.

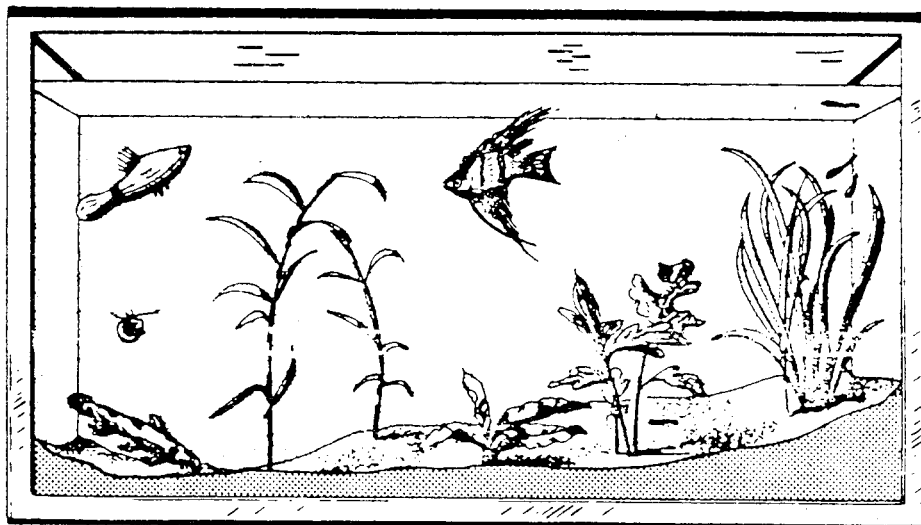

No food, water or air was added to the aquarium for three months. The water level remained the same and the plants, fish, snails, and other water animals continued to live and thrive. What did this prove?

- (A) Fish do not require oxygen.
- (B) Water plants do not require oxygen.
- (C) Snails do not require oxygen.
- (D) It did not prove any of these things.

N404601

54. A medical researcher wanted to find out what caused a certain disease. She gathered the following information from different places in the world.

	Major Type of Food	Type of Area	Mosquitoes	Disease
Country 1	Fish only	City	Yes	Yes
Country 2	Meat and vegetables	Farmland	No	No
Country 3	Fish and rice	City	No	Yes
Country 4	Fish only	Farmland	Yes	Yes

Which one of the following would be best for the researcher to study more closely in order to find the cause of the disease?

- (A) Major type of food
 (B) Type of area
 (C) Mosquitoes
 (D) Swamps
- N411201
55. As an experiment, Mary grew some plants in the refrigerator and some plants on the window sill. She watered the ones on the window sill every day. For two days she forgot to water the ones in the refrigerator. The plants on the window sill grew 4 centimeters. The plants in the refrigerator grew 2 centimeters.

Why couldn't Mary say the plants on the window sill grew taller just because they were in a warmer place?

- (A) Because the plants on the window sill got more water than those in the refrigerator
 (B) Because she used the same kinds of plants in each place
 (C) Because she used the same sized pots
- N411502
56. The Pacific Ocean is surrounded by a large belt of mountain ranges and volcanoes. Which natural events are most closely associated with these landforms?

- (A) Hurricanes
 (B) Tornadoes
 (C) Sandstorms
 (D) Earthquakes
- N420401

57. The shape of the Earth's shadow during an eclipse of the Moon indicates that the shape of the Earth CANNOT be which of the following?

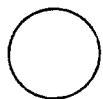

(A) A Sphere

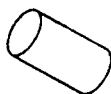

(B) A Cylinder



(C) A Cone



(D) A Cube

N435101

58.

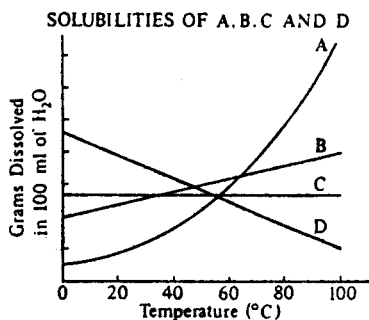

According to the graph above, which of the chemicals is most soluble in water at 90°C?

- (A) A
 (B) B
 (C) C
 (D) D
- N427501

WHEN YOU HAVE FINISHED

Please check to make sure you have marked *one* answer for each question. When you have checked your answers, place your *Answer Sheet* inside the front cover of the test booklet. All of the booklets will be collected at the same time after everyone is finished. Please sit quietly while others are completing their work.

LONGITUDINAL STUDY OF AMERICAN YOUTH

SCIENCE TEST (FORM E)

Student's Name

CORRECT MARK
A B C ● E

INCORRECT MARKS
X ○ / ⊖ ⊖

- Use black lead No. 2 pencil.
- Make heavy marks the full length of the boxes.
- Make only one mark per question.
- Erase cleanly any unintended marks.

PAGE 1

- 1 A B C D
2 A B C
3 A B
4 A B C D
5 A B C D
6 A B C D

PAGE 2

- 7 A B C D E
8 A B C D
9 A B C D
10 A B C D
11 A B C D

PAGE 3

- 12 A B C
13 A B C
14 A B C D
15 A B C
16 A B C D E
17 A B
18 A B
19 A B
20 A B
21 A B

PAGE 4

- 22 A B C D
23 A B C D
24 A B C D E
25 A B C D
26 A B C D E
27 A B C D

PAGE 5

- 28 A B C
29 A B C D
30 A B C D
31 A B
32 A B C D

PAGE 6

- 33 A B C
34 A B C D
35 A B C
36 A B C D

PAGE 7

- 37 A B C D
38 A B C D
39 A B C D
40 A B C D

PAGE 8

- 41 A B
42 A B C
43 A B C D
44 A B C D
45 A B C D

PAGE 9

- 46 A B C
47 A B C D
48 A B C D
49 A B C D
50 A B C D E

PAGE 10

- 51 A B C D
52 A B C D
53 A B C D

PAGE 11

- 54 A B C D
55 A B C
56 A B C D
57 A B C D
58 A B C D

FOR LSAY USE ONLY

0	0	0	0	0	0
1	1	1	1	1	1
2	2	2	2	2	2
3	3	3	3	3	3
4	4	4	4	4	4
5	5	5	5	5	5
6	6	6	6	6	6
7	7	7	7	7	7
8	8	8	8	8	8
9	9	9	9	9	9